

17 Attachments

17.1	Drawbar	17-3
17.1.1	Remove the drawbar	17-3
17.1.2	Install the drawbar	17-5
17.2	Drawbar maintenance	17-7
17.2.1	Replace the wear plates and the rubber stops on the standard drawbar	17-7
17.2.2	Category four pin with adapter plate for the category five drawbar	17-7
17.3	Ballasting	17-8
17.3.1	Ballast guide lines	17-8
17.3.2	General guide lines	17-8
17.3.3	Tire pressure	17-8
17.3.4	Power hop control	17-8
17.3.5	Ballast recommendations for the special application machine	17-9
17.3.6	Weight splits	17-9
17.3.7	Ballast packages	17-9
17.3.8	Heavy vertical hitch loads	17-11
17.3.9	Ballast work sheet	17-13
17.3.10	Tire inflation guide	17-16
17.3.11	Calculate wheel slippage for machines without a speed sensor	17-20
17.4	Weight removal and installation	17-21
17.4.1	Remove the front weights	17-21
17.4.2	Install the front weights	17-23
17.4.3	Remove the wheel weights	17-26
17.4.3.1	227 kg (500 lb)	17-26
17.4.3.2	364 kg (800 lb)	17-27
17.4.4	Install the wheel weights	17-28
17.4.4.1	227 kg (500 lb)	17-28
17.4.4.2	364 kg (800 lb)	17-29
17.5	Toolbox	17-31
17.5.1	Remove the toolbox	17-31
17.5.2	Install the toolbox	17-32
17.6	Special application hitch	17-34
17.6.1	Remove the special application hitch	17-34
17.6.2	Install the special application hitch	17-36
17.7	Tow cable	17-38
17.7.1	Remove the tow cable	17-38
17.7.2	Install the tow cable	17-39

17.1 Drawbar

17.1.1 Remove the drawbar

Procedure

1. Park the machine on a solid, level surface. Stop the engine, apply the parking brake, and take the key with you.
2. Turn the battery disconnect switch key (1) counterclockwise to disconnect the battery power.

NOTE:

The battery disconnect switch is shown in the off position.

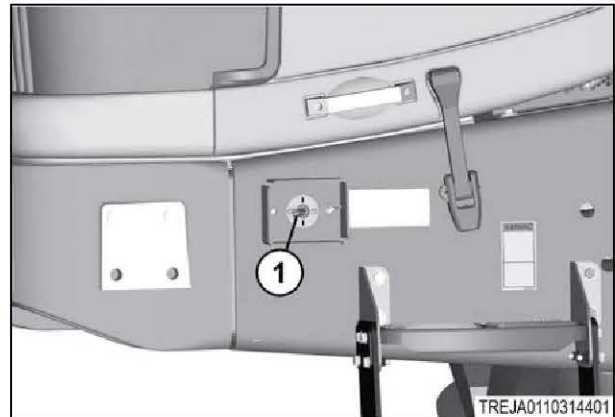

Fig. 1

3. Remove the battery disconnect switch key (1).

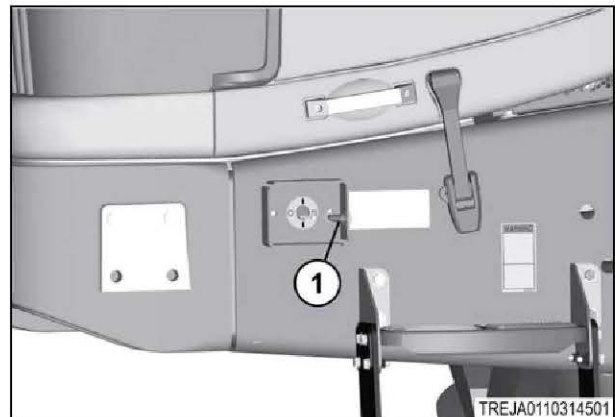

Fig. 2

4. Remove the hitch pin (1).

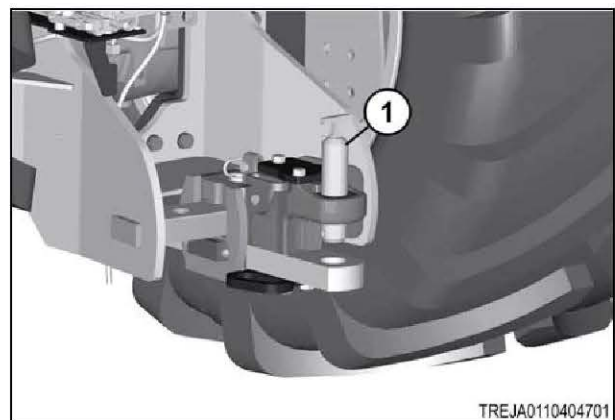

Fig. 3

17. Attachments

5. Remove the hardware (1), the cover plate (2), the locking plate, and the chain support plate (3).

IMPORTANT:

The weight of the clevis is approximately 19 kg (41 lb).

6. Remove the clevis and the dowel pin.

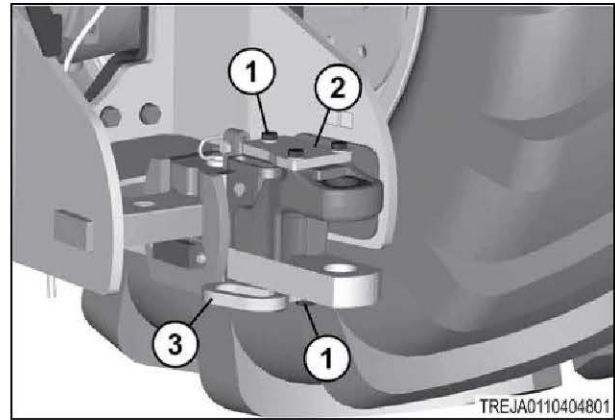

Fig. 4

7. Release the lock mechanism (1), and remove the pin (2).

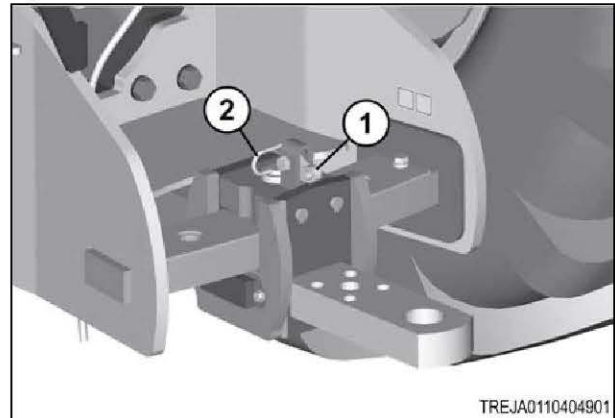

Fig. 5

8. Remove the hardware (1), and the drawbar pin (2), from the drawbar (3).

9. Connect the correct lifting equipment to the drawbar.

IMPORTANT:

The weight of the drawbar is approximately 169 kg (373 lb).

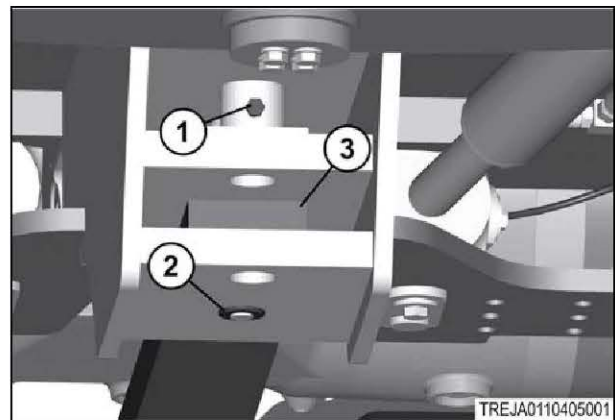

Fig. 6

10. Slide the drawbar (1) out the rear of the machine.

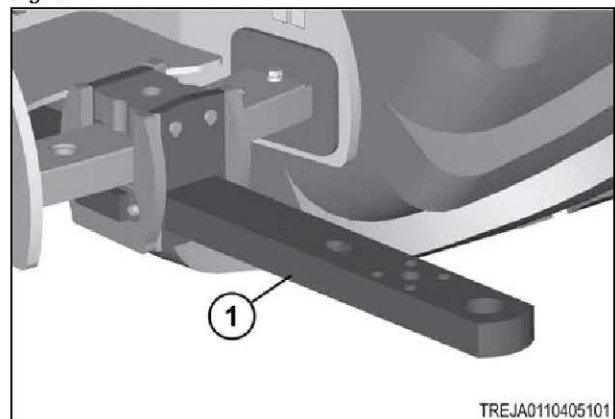

Fig. 7

17.1.2 Install the drawbar

Procedure

1. Slide the drawbar (1) in the rear of the machine.

IMPORTANT:

The weight of the drawbar is approximately 169 kg (373 lb).

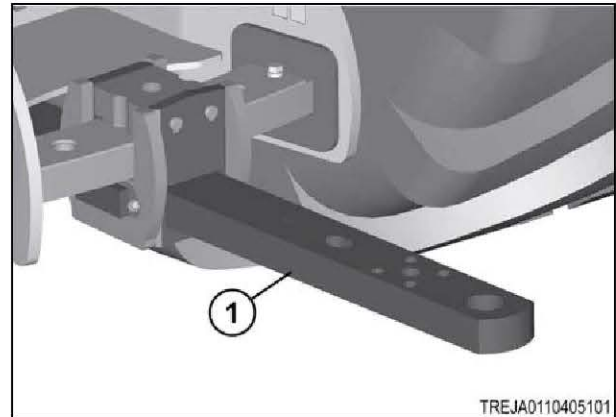

Fig. 8

2. Install the drawbar pin (2) in the drawbar (3), with the hardware (1).

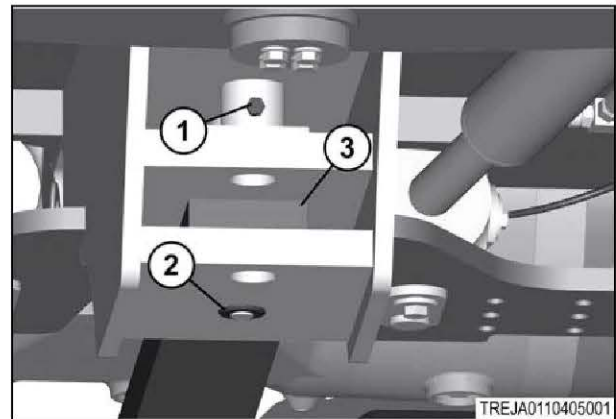

Fig. 9

3. Install the pin (2) and connect the lock mechanism (1).

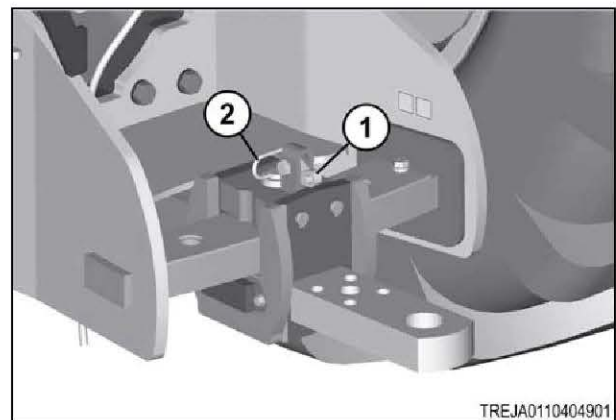

Fig. 10

17. Attachments

4. Install the locking plate, the chain support plate (3), and the cover plate (2) with the hardware (1).

IMPORTANT:

The weight of the clevis is approximately 19 kg (41 lb).

5. Install the dowel pin and the clevis.

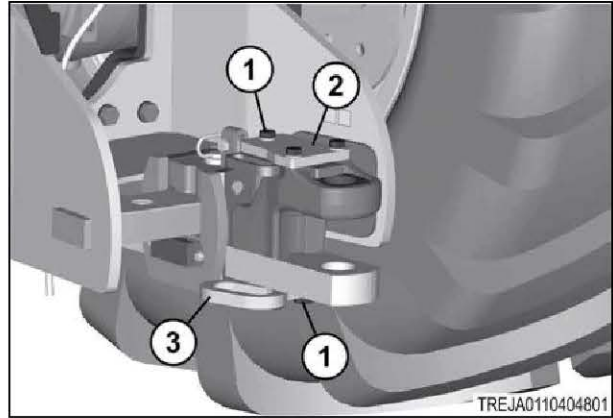

Fig. 11

6. Install the hitch pin (1).

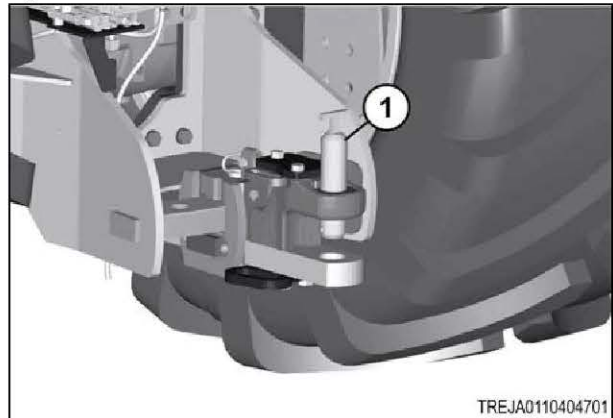

Fig. 12

7. Install the battery disconnect switch key (1).

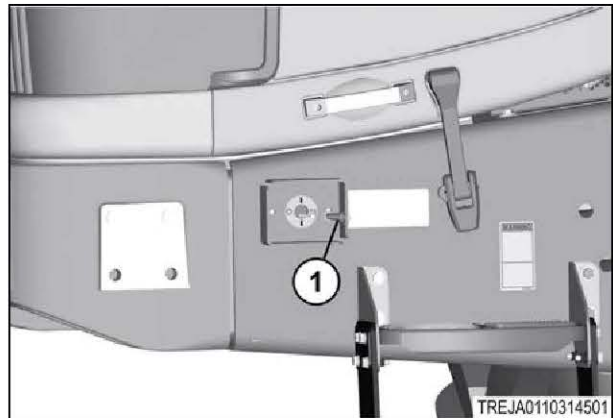

Fig. 13

8. Turn the battery disconnect switch key (1) clockwise to connect the battery power.

NOTE:

The battery disconnect switch is shown in the on position.

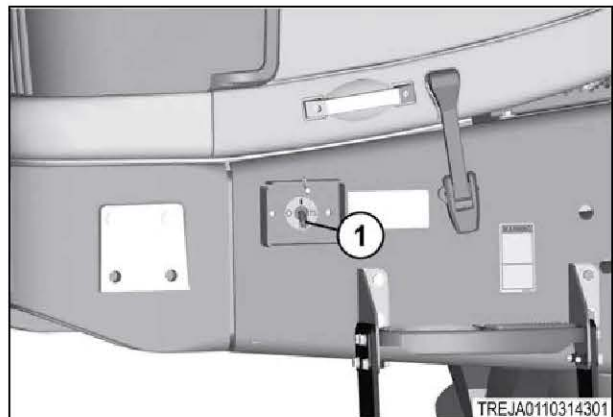

Fig. 14

17.2 Drawbar maintenance

17.2.1 Replace the wear plates and the rubber stops on the standard drawbar

Standard drawbar

Procedure

1. There are two replaceable rubber stops (1) on each side of the standard drawbar.
2. There is a total of two bolts and two washers (2) to remove the rubber stops.
There is also a wear plate (3) that the drawbar slides on.

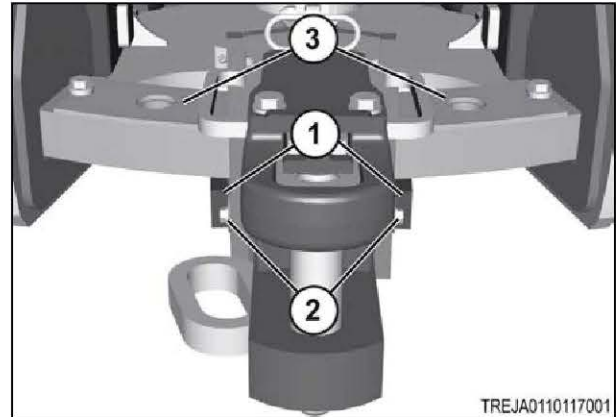

Fig. 15

3. Remove the screws (1) and replace the wear plate as needed.

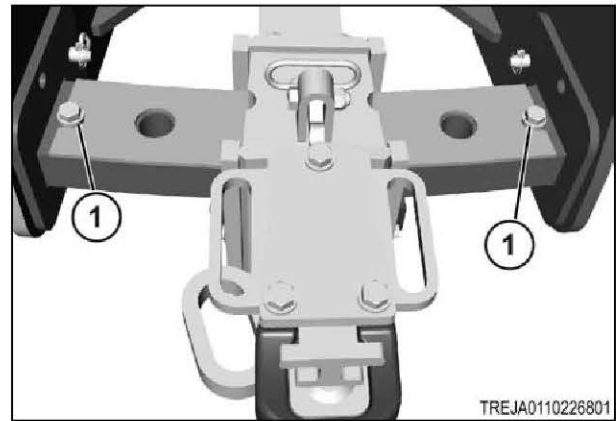

Fig. 16

17.2.2 Category four pin with adapter plate for the category five drawbar

Procedure

1. Use the adapter pin only (1) with the adapter plate installed. This reduces the hole diameter in the drawbar. The shoulder of the category four pin fits the category five hole.
2. To prevent the adapter from rotating, make sure the plate fits correctly in the notch (2).

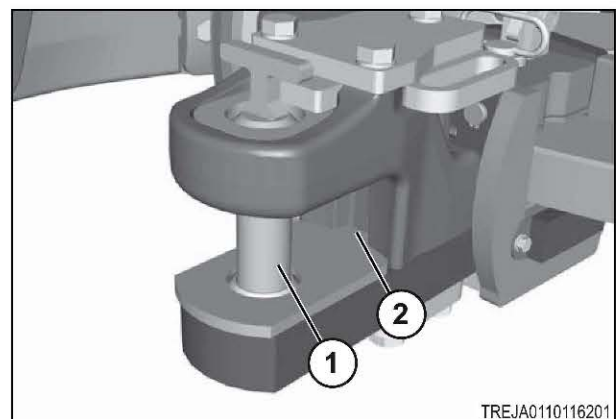

Fig. 17

17.3 Ballasting

17.3.1 Ballast guide lines

To get best performance, ride comfort and long tire life, machine must be ballasted and the tire pressure set correctly. Use guidelines in this section to determine correct ballast configuration.

17.3.2 General guide lines

IMPORTANT: *Additional ballast may be required for proper balance with PTO and/or 3 point hitch options installed. Maximum laden weight must not be more than 27216 kg (60000 lbs).*

- Set and keep the machine balance, ballast and tire pressures per recommendations in this section. A ballasting worksheet is provided for this purpose. For reference, an example is provided. See the information under Heavy vertical hitch loads for tire pressure adjustments if pulling 3-point linkage equipment, scraper pans or the other implements transmitting vertical hitch loads to machine.
- Liquid tire ballast is not recommended. Always use cast iron wheel weights and/or front suitcase weights for ballasting.
- The recommended operating weight is 45 kg to 54 kg to (99 to 119 lb) per engine kiloWatt kW/kg (horsepower hp/lb). Higher speeds and lighter draft loads demand less weight per kW (hp) and can be possible to reduce machine ballast.
- A correctly balanced and ballasted machine, operating with correct tire pressures must have tire slip in range of 6 to 12 percent when operating under load. This amount of slip is normal and necessary to cause correct drawbar kiloWatt (horsepower).
- Do not try to operate at full or heavy loads below 6.4 km/h (4 mph). Continued operation below this speed shortens the powertrain life. Never operate above maximum ballasted weight for machine model.

17.3.3 Tire pressure

The effects of over inflation include:

- Rough ride
- Reduced fuel economy
- Increased tire wear because of excessive wheel slip
- Not good enough power hop control
- Reduced drawbar hp

The effects of under inflation include:

- Reduced tire life because of excessive sidewall bending
- Increased chance of tire damage and tire to wheel slip
- Increased rolling resistance

Never fill past the maximum rated pressure told on the tire sidewall.

Set all tires on the same axle to the same pressure.

Do not operate with radial tires below 41 kPa (5.9 psi) minimum pressure.

When operating on side hill conditions, increase tire pressure by 28 kPa (4 psi) to adjust for side-to-side weight transfer.

17.3.4 Power hop control

Power hop is loss of traction when a machine pulls an implement at medium to high draft load in loose, dry soil or up hill.

Setting all the tires to the correct air pressure for the axle load usually corrects most of the power hop issues. If power hop occurs again after the tire pressures are corrected, do the following procedure:

1. Adjust the weight split front to rear can help decrease power hop.
2. Make sure the machine is balanced per guidelines in table two (see the information for ballast recommendations) and weight/hp is minimum 48 kg/HP. Adjust the ballast if necessary and set all the tires to the recommended pressures. See the information on heavy vertical hitch loads for additional tire pressure information.
3. Test the machine again for power hop. If power hop occurs, increase the pressure in all rear tires by 41 kPa (6 psi) and test again.
4. Continue to increase the rear tire pressure 41 kPa (6 psi) at a time, until there is no power hop or at the maximum tire pressure.

17.3.5 Ballast recommendations for the special application machine

Ballasting the machine correctly will be crucial to get optimal performance. There are factors to consider when selecting the correct weight to add to the machine:

- Machine horsepower
- Scraper size being used
- Terrain
- Soil conditions

Machine base weight	
Tire option	Weight
620/70R46, 650/85R38, 710/70R38 Duals	Approximately 20 865 kg (46 000 lb)
710/70R42 and 800/70R38 Duals	Approximately 21 546 kg (47 500 lb)
1100/45R46 Single tire	Approximately 19 550 kg (43 100 lb)
35.5L-32 Single tire	Approximately 18 733 kg (41 300 lb)

The machine must be ballasted up to its maximum permitted weight to get maximum performance.

Machine maximum ballasted weight	
MT955E	24 494 kg (54 000 lb)
MT965E	27 216 kg (60 000 lb)
MT975E	27 216 kg (60 000 lb)

Ballasting will be achieved with a combination of the weights mounted on the wheels of the machine and the front mounted suitcase weights. The other major factor to consider is the tire air pressure. Having the correct weight on the machine will not produce ideal performance if the tires are incorrectly inflated.

17.3.6 Weight splits

It is recommended that all special application machines be configured in a 65 Front / 35 Rear weight split. This is required due to extreme load transfers in scraper applications. When under load and hauling, this weight split will create optimum traction by bringing the entire machine-scraper system to an even weight split.

17.3.7 Ballast packages

The weight options detailed below weights the machine to its maximum allowable weight.

MT955E

Tire option	Ballasting weight	Total weight
620/70R46, 650/85R38 and 710/70R38 Duals	6 Total Weights on Rear Axle 1361 kg (3000 lb) 6 Total Weights on Front Axle 1361 kg (3000 lb) 20 Front Weights 1422 kg (3137 lb)	24494 kg (54000 lb)
710/70R42, 800/70R38 and IF800/70R38 Duals	4 Total Weights on Rear Axle 907 kg (2000 lb) 4 Total Weights on Front Axle 907 kg (2000 lb) 20 Front Weights 1422 kg (3137 lb)	24494 kg (54000 lb)
35.5L-32 Single Tire	6 Total Weights on Rear Axle 2177 kg (4800 lb) 6 Total Weights on Front Axle 2177 kg (4800 lb) 20 Front Weights 1422 kg (3137 lb)	24494 kg (54000 lb)
1100/45R46 Single Tire	6 Total Weights on Rear Axle 1361 kg (3000 lb) 6 Total Weights on Front Axle 1361 kg (3000 lb) 32 Front Weights 1976 kg (4356 lb)	24494 kg (54000 lb)

MT965E and MT975E

Tire option	Ballasting weight	Total weight
620/70R46, 650/85R38, 710/70R38 and 710/70R42 Duals	10 Total Weights on Front Axle 2268 kg (5000 lb) 8 Total Weights on Rear Axle 1814 kg (4000 lb) 32 Front Weights 1976 kg (4356 lb)	27216 kg (60000 lb)
800/70R38 and IF800/70R38 Duals	8 Total Weights on Rear Axle 1814 kg (4000 lb) 8 Total Weights on Front Axle 1814 kg (4000 lb) 32 Front Weights 1976 kg (4356 lb)	27216 kg (60000 lb)
35.5L-32 Single Tire	8 Total Weights on Rear Axle 2903 kg (6400 lb) 8 Total Weights on Front Axle 2903 kg (6400 lb) 32 Front Weights 1976 kg (4356 lb)	27216 kg (60000 lb)
1100/45R46 Single Tire	10 Total Weights on Rear Axle 2268 kg (5000 lb) 10 Total Weights on Front Axle 2268 kg (5000 lb) 32 Front Weights 1976 kg (4356 lb)	27216 kg (60000 lb)

17.3.8 Heavy vertical hitch loads

Adjustments to the rear tire pressures are required to support any additional axle loads that are generated by heavy rear-mounted implements. Other loads can include 3-point linkage equipment (not available), scraper pans and grain carts. Because of the variations in equipment and loads, best method to determine correct rear tire pressures is to:

1. Measure the rear axle weight with a scale while the heavy hitch load is supported by the machine.
2. See the information on the tire inflation guide to determine the correct rear tire pressure, based on the measured axle weight.

17. Attachments

An alternate method is to measure the amount of rear tire deflection. This method is not as accurate but can be used if measuring the rear axle weight is not possible. Use the following procedure for this method:

1. Park the machine on a level surface and then support the mounted equipment at the equipment's maximum operating weight.
2. Measure (1) the distance between the center of the hole (2) and the ground (3).
3. Determine the height measurement reference for the tires installed on machine by using the tire inflation guide. Compare the value to the measurement taken in Step 2. If the reference and the actual measurements are not within 6.4 mm, adjust the pressure in all the rear tires by 4 psi and repeat Steps 2 and 3. Do not go higher than the maximum tire pressure recorded on the tire sidewall.

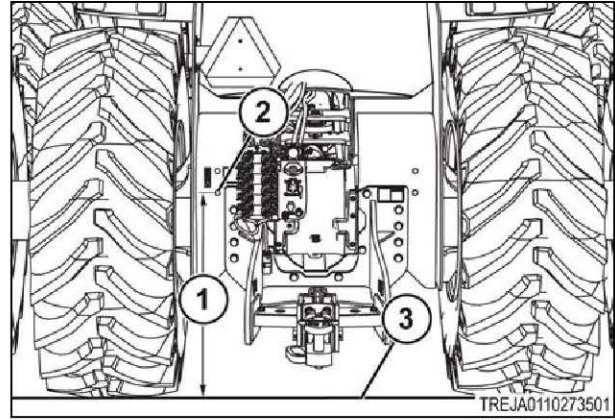

Fig. 18

17.3.9 Ballast work sheet

MT900 Ballast worksheet

TRACTOR CONFIGURATION: _____

Model: _____ Tire Size: _____
 Hitch Type: _____ Lbs/Hp Goal: _____
 PTO: _____ % Weight Goal on Front Axle: _____

1. DETERMINE IDEAL AXLE WEIGHTS
 Ideal axle weights will be the ballasting goal for tractor.
 Total tractor weight (from Table 1): _____ lbs
 Multiply by % weight on front axle (from Table 2): _____ lbs
 Ideal FRONT axle weight = _____ lbs
 Enter total tractor weight (from Table 1) again: _____ lbs
 Subtract Ideal FRONT axle weight: _____ lbs
 Ideal REAR axle weight = _____ lbs

2. CALCULATE UNBALLASTED TRACTOR WEIGHT
 This step calculates the total unballasted tractor weight, based on tire selection and whether PTO or a 3-point hitch is installed. ENTER ZEROS FOR ANY OPTION NOT INSTALLED.

	FRONT Axle Weight	REAR Axle Weight
Base Tractor Axle Weights (from Table 3):		lbs
Add for optional PTO (from Table 4): +		lbs
SUBTOTAL =		lbs
Add/Subtract for optional 3-Point Hitch (from Table 4): -		lbs
UNBALLASTED TRACTOR WEIGHT =		lbs

3. CALCULATE BALLAST NEEDED
 Enter amounts from previous two steps to determine the amount of ballast needed at the front and rear axles.
 Subtract Ideal Axle Weights (from Step 1): - _____ lbs
BALLAST NEEDED = _____ lbs

NOTE: Values for BALLAST NEEDED will likely be negative, indicating that ballast is needed to achieve the ideal weight goal. If either amount is a positive number greater than 800 lbs, do one (or more) of the following and recalculate before proceeding:
 - Choose a new weight from Table 1, corresponding to a higher lb/hp for your tractor
 - Vary the % weight on front axle within the guidelines in Table 2

4. INSTALL FRONT SUITCASE WEIGHTS (optional)
 If BALLAST NEEDED for front axle is greater than 1800 lbs, front suitcase weights can be added, minimizing or eliminating the need for counterweights inside the front wheels. If front suitcase weights are desired, use Table 5 to determine which front weight option is closest to front ballast needed. ENTER ZEROS IF NO SUITCASE WEIGHTS WILL BE USED.

Add/Subtract for Front Counterweights (from Table 5): +	-	lbs
WHEEL WEIGHT REQUIREMENT =		lbs

5. INSTALL WHEEL WEIGHTS
 Choose wheel weight sizes from Table 6 that are compatible with your tire arrangement (i.e. singles, duals or triples). Determine the number of wheel weights that will be needed to meet the remaining wheel weight requirement above. Weights must be chosen two per axle.

FRONT wheel weights: _____ (weights) x _____ (lbs) = + _____ lbs
 REAR wheel weights: _____ (weights) x _____ (lbs) = + _____ lbs
 AMOUNT OVER (or under, if negative) IDEAL WEIGHT = _____ lbs

6. CHECK TOTAL TRACTOR WEIGHT
 Ideal Axle Weights (from Step 1): + _____ lbs
TOTAL AXLE WEIGHTS = _____ lbs
 Add front and rear TOTAL AXLE WEIGHTS together to obtain TOTAL TRACTOR WEIGHT = _____ lbs

MAXIMUM BALLASTED WEIGHTS: MT945B = 50000 lb, MT955B = 54000 lb, MT965B & MT975B = 60000 lb
 Do not exceed the maximum ballasted weight for your tractor

TREJA0110273601

Fig. 19

Table 1

Machine weight guidelines			
	MT955E	MT965E	MT975E
	(500 hp)	(550 hp)	(600 hp)
100 lb/hp	46000	51000	57000
105 lb/hp	48300	53550	59850
110 lb/hp	50600	56100	60000
115 lb/hp	52900	58650	60000
120 lb/hp	54000	60000	60000

Table 2

Percent weight on front axle		
Drawbar only	three-point linkage	Towed scraper
55-60 percent	60-70 percent	65-70 percent

Table 3

MT900E Base machine axle weights		
Tire and wheel arrangements	Front	Rear
620/70R42 Duals	35282	17456
620/70R46 Duals	35517	17493
650/85R38 Duals	35489	17553
710/70R38 Duals	35452	17541
710/70R42 Duals	35829	17887
800/70R38 Duals	36171	18698
IF800/70R38 Duals	36378	18491
480/80R46 Triples	36226	18331
480/80R50 Triples	36929	19024
520/85R42 Triples	36287	18362
520/85R46 Triples	36916	19004
35.5-32LS Singles	33721	15796
1100/45R46 Singles	34649	16683

Table 4

Machine options	Front	Rear
PTO - add	+228	+722
Three-point linkage - add/subtract	-405	+2904

Table 5

Front counterweights	Front	Rear
Front bracket only	+1738	-672
Bracket +20 suitcase weights	+5167	-2030
Bracket +32 suitcase weights	+7202	-2846

Table 6

Wheel weights	Front and rear axle
Duals/Triples - add	500 lb each
Singles - add	800 lb each

TRACTOR CONFIGURATION: _____

Model: MT965B Tire Size: 800/70R38
 Hitch Type: Drawbar Lbs/Hp Goal: 120 lb/hp
 PTO: No % Weight Goal on Front Axle: 55%

1. DETERMINE IDEAL AXLE WEIGHTS
 Ideal axle weights will be the ballasting goal for tractor.

Total tractor weight (from Table 1): 60000 lbs
 Multiply by % weight on front axle (from Table 2): 0.55
Ideal FRONT axle weight = 33000 lbs

Enter total tractor weight (from Table 1) again: 60000 lbs
 Subtract Ideal FRONT axle weight: 33000 lbs
Ideal REAR axle weight = 27000 lbs

2. CALCULATE UNBALLASTED TRACTOR WEIGHT
 This step calculates the total unballasted tractor weight, based on tire selection and whether PTO or a 3-point hitch is installed. ENTER ZEROS FOR ANY OPTION NOT INSTALLED.

	FRONT Axle Weight	REAR Axle Weight
Base Tractor Axle Weights (from Table 3):	27909	19801 lbs
Add for optional PTO (from Table 4): +	0	0 lbs
SUBTOTAL =	27909	19801 lbs
Add/Subtract for optional 3-Point Hitch (from Table 4): -	0	0 lbs
UNBALLASTED TRACTOR WEIGHT =	27909	19801 lbs

3. CALCULATE BALLAST NEEDED
 Enter amounts from previous two steps to determine the amount of ballast needed at the front and rear axes.

Subtract Ideal Axle Weights (from Step 1): -	33000	27000 lbs
BALLAST NEEDED =	-5091	-7199 lbs

NOTE: Values for BALLAST NEEDED will likely be negative, indicating that ballast is needed to achieve the ideal weight goal. If either amount is a positive number greater than 800 lbs, do one (or more) of the following and recalculate before proceeding:
 - Choose a new weight from Table 1, corresponding to a higher lb/hp for your tractor
 - Vary the % weight on front axle within the guidelines in Table 2

4. INSTALL FRONT SUITCASE WEIGHTS (optional)
 If BALLAST NEEDED for front axle is greater than 1800 lbs, front suitcase weights can be added, minimizing or eliminating the need for counterweights inside the front wheels. If front suitcase weights are desired, use Table 5 to determine which front weight option is closest to front ballast needed. ENTER ZEROS IF NO SUITCASE WEIGHTS WILL BE USED.

Add/Subtract for Front Counterweights (from Table 5): +	5167	2030 lbs
WHEEL WEIGHT REQUIREMENT =	76	-9229 lbs

5. INSTALL WHEEL WEIGHTS
 Choose wheel weight sizes from Table 6 that are compatible with your tire arrangement (i.e. singles, duals or triples). Determine the number of wheel weights that will be needed to meet the remaining wheel weight requirement above. Weights must be chosen two per axle.

FRONT wheel weights: _____ (weights) x _____ (lbs) = +	0	
REAR wheel weights: _____ (weights) x _____ (lbs) = +		9000
AMOUNT OVER (or under, if negative) IDEAL WEIGHT =	76	-229 lbs

6. CHECK TOTAL TRACTOR WEIGHT

Ideal Axle Weights (from Step 1): +	33000	27000 lbs
TOTAL AXLE WEIGHTS =	33076	26771 lbs
Add front and rear TOTAL AXLE WEIGHTS together to obtain TOTAL TRACTOR WEIGHT =	59847	lbs

MAXIMUM BALLASTED WEIGHTS: MT945B = 50000 lb, MT955B = 54000 lb, MT965B & MT975B = 60000 lb

TREJA0110273701

Fig. 20

17.3.10 Tire inflation guide

IMPORTANT: Do not exceed the manufacturer's maximum inflation value stamped on the tire sidewall.

NOTE: Recommended tire pressure for 35.5L-32 24PR tires used in scraper applications is a minimum of 30 psi (207 kPa) front and rear. Severe conditions and/or pans 18 m (20 yd) or larger may require a maximum of 35 psi (241 kPa).

Dual tires

Axle Weight (lbs)	620/70 R46 LI 162 Duals	650/85 R38 LI 173 Duals	710/70 R38 LI 166 Duals	710/70 R42 LI 173 Duals	800/70 R38 LI 173 Duals	IF800/70 R38 (axioBib) LI 179 Duals
18000	7	6	6	6	6	6
18500	8	6	6	6	6	6
19000	8	6	6	6	6	6
19500	8	6	6	6	6	6
20000	9	6	7	7	6	6
20500	9	7	7	7	6	6
21000	10	7	8	7	6	6
21500	10	7	8	8	6	6
22000	11	8	8	8	6	6
22500	11	8	9	8	6	6
23000	11	8	9	9	6	6
23500	12	9	9	9	7	6
24000	12	9	10	10	7	6
24500	13	10	10	10	7	6
25000	13	10	11	10	8	6
25500	14	10	11	11	8	6
26000	14	11	11	11	8	6
26500	14	11	12	11	9	6
27000	15	11	12	12	9	6
27500	15	12	13	12	9	6
28000	16	12	13	12	9	6
28500	16	13	13	13	10	7
29000	17	13	14	13	10	7
29500	17	13	14	13	10	7
30000	17	14	15	14	11	7
30500	18	14	15	14	11	8
31000	18	15	15	14	11	8
31500	19	15	16	15	12	8
32000	19	15	16	15	12	9
32500	20	16	16	16	12	9
33000	20	16	17	16	13	9
33500	20	16	17	16	13	9
34000	21	17	18	17	13	10
34500	21	17	18	17	13	10
35000	22	18	18	17	14	10

Axle Weight (lbs)	620/70 R46 LI 162 Duals	650/85 R38 LI 173 Duals	710/70 R38 LI 166 Duals	710/70 R42 LI 173 Duals	800/70 R38 LI 173 Duals	IF800/70 R38 (axioBib) LI 179 Duals
35500	22	18	19	18	14	10
36000	23	18	19	18	14	11
36500	23	19	20	18	15	11
37000	-	19	20	19	15	11
37500	-	19	20	19	15	11
38000	-	20	21	19	16	12
38500	-	20	21	20	16	12
39000	-	21	21	20	16	12
39500	-	21	22	20	16	12
40000	-	21	22	21	17	13
40500	-	22	23	21	17	13
41000	-	22	23	22	17	13
41500	-	22	23	22	18	14
42000	-	23	-	22	18	14
Maximum pressure (psi)	23 psi	35 psi	23 psi	35 psi	23 psi	23 psi
Avg. static load	36.4	35.7	33.8	36.3	35.7	N/A
Height measurement	44.3	43.6	41.7	44.2	43.6	N/A

Triple tires

Axle Weight (lbs)	480/80 R46 LI 158 Triples	480/80 R50 LI 159 Triples	520/85 R42 LI 157 Triples	520/85 R46 LI 158 Triples	520/85 R46R2 Rice & Cane LI 158 Triples
18000	6	6	6	6	6
18500	7	6	6	6	6
19000	7	6	6	6	6
19500	8	7	6	6	6
20000	8	7	6	6	6
20500	8	7	6	6	6
21000	9	8	7	6	6
21500	9	8	7	6	6
22000	10	9	7	7	7
22500	10	9	8	7	7
23000	10	9	8	7	7
23500	11	10	8	8	8

Axle Weight (lbs)	480/80 R46 LI 158 Triples	480/80 R50 LI 159 Triples	520/85 R42 LI 157 Triples	520/85 R46 LI 158 Triples	520/85 R46R2 Rice & Cane LI 158 Triples
24000	11	10	9	8	8
24500	12	11	9	8	8
25000	12	11	9	9	9
25500	12	11	10	9	9
26000	13	12	10	9	9
26500	13	12	10	10	10
27000	14	13	11	10	10
27500	14	13	11	10	10
28000	14	13	11	11	11
28500	15	14	12	11	11
29000	15	14	12	11	11
29500	16	14	13	12	12
30000	16	15	13	12	12
30500	16	15	13	13	13
31000	17	16	14	13	13
31500	17	16	14	13	13
32000	18	16	14	14	14
32500	18	17	15	14	14
33000	18	17	15	14	14
33500	19	18	15	15	15
34000	19	18	16	15	15
34500	20	18	16	15	15
35000	20	19	16	16	16
35500	20	19	17	16	16
36000	21	20	17	16	16
36500	21	20	17	17	17
37000	22	20	18	17	17
37500	22	21	18	17	17
38000	22	21	19	18	18
38500	23	21	19	18	18
39000	23	22	19	18	18
39500	24	22	20	19	19
40000	24	23	20	19	19
40500	24	23	20	19	19
41000	25	23	21	20	20
41500	25	24	21	20	20

Axle Weight (lbs)	480/80 R46 LI 158 Triples	480/80 R50 LI 159 Triples	520/85 R42 LI 157 Triples	520/85 R46 LI 158 Triples	520/85 R46R2 Rice & Cane LI 158 Triples
42000	26	24	21	20	20
Maximum pressure (psi)	35 psi	35 psi	23 psi	23 psi	23 psi
Avg. static load	35.1	37.1	34.4	36.4	37.4
Height measurement	43.0	45.0	42.3	44.3	45.3

17.3.11 Calculate wheel slippage for machines without a speed sensor

If the machine is not equipped with a ground speed sensor, use the following procedure to determine tire slippage.

Procedure

1. Mark a spot (1) on the side of the tire with a piece of tape or chalk. Also, mark the corresponding spot (2) on ground.
2. Operate the machine with the implement in raised position for three full revolutions (A) of the tire.
3. Clearly mark a spot (3) on the ground at end of the third full revolution of the tire.
4. Return to initial starting point (2) and then mark a new spot on side of the tire.
5. Move the machine in rearward direction to get the implement in a working position by the starting point (2). Lower the implement to a working depth.
6. Operate the machine with the implement in a lowered position for three full revolutions (A) of the tire. Make sure the machine is operating at a desired working speed.
7. Measure the slip distance (B). The slip distance is the length from the end point (4) of the second run to the end point (3) of the first run.
8. The percent of slippage is the distance (B) divided by (A), then multiplied by 100.

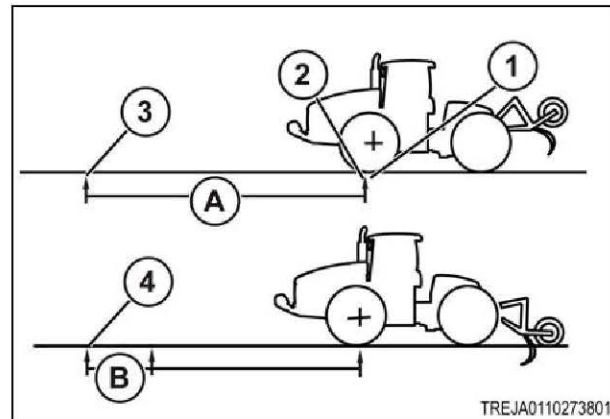

Fig. 21

TREJA0110273801

17.4 Weight removal and installation

17.4.1 Remove the front weights

Procedure

1. Remove the bolts (1) that secure the weights.

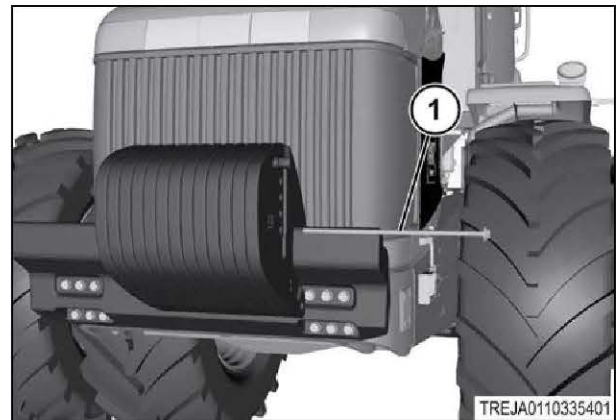

Fig. 22

2. Remove the weights (1) from the front bracket.

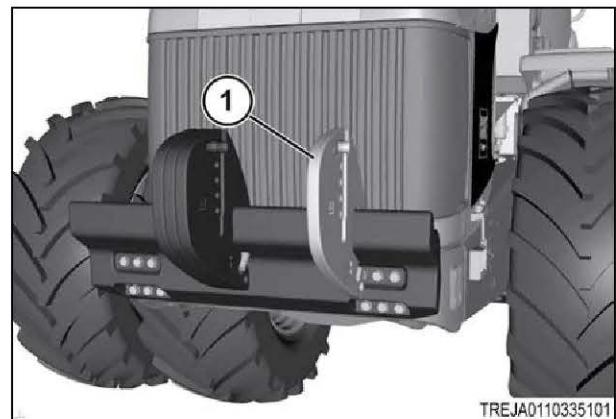

Fig. 23

3. Remove the plates (1) from the weights.



Fig. 24

17. Attachments

4. Continue removing the weights (1) on both sides of the flagpin until all the weights are removed.

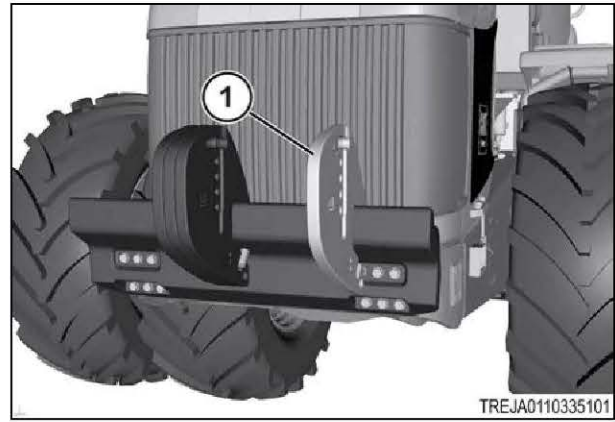

Fig. 25

5. Remove the bolt (1) that secures the flagpin.

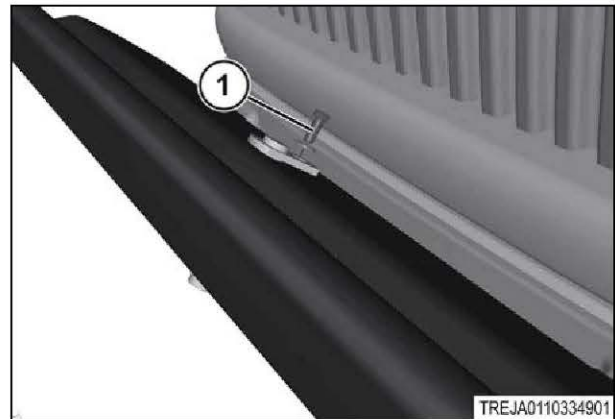

Fig. 26

6. Remove the flagpin (1).

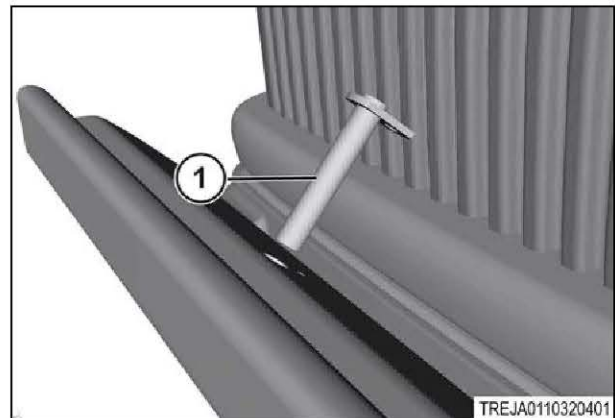

Fig. 27

7. Using a suitable lifting device, support the front weight mounting bracket (1). Remove the twelve bolts (2) that secure the bracket. Remove the mounting bracket.



Fig. 28

- Install plugs (1) to the front of the machine.

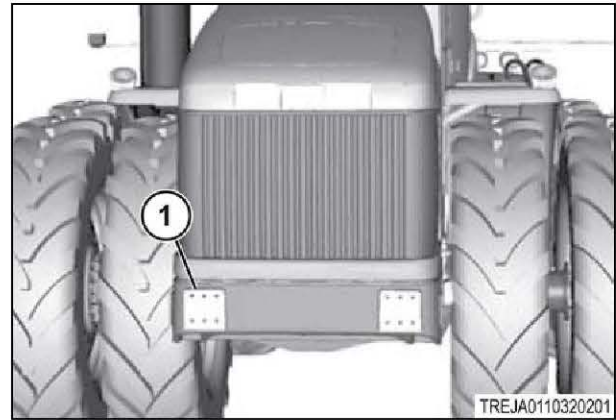

Fig. 29

17.4.2 Install the front weights



WARNING:

The front weights are extremely heavy and require correct handling equipment to remove. Fully support and constrain tire and wheel assemblies prior to removing the weights. Failure to use the correct procedures and correct equipment can cause personal injury or can cause death because of crushing.

Procedure

- Remove the plugs (1) from the front of the machine.
- Using a suitable lifting device, move the front weight mounting bracket (1) into position. The weight of the bracket is approximately 499 kg. Install the bracket with twelve bolts and washers (2). Torque to 530 Nm.

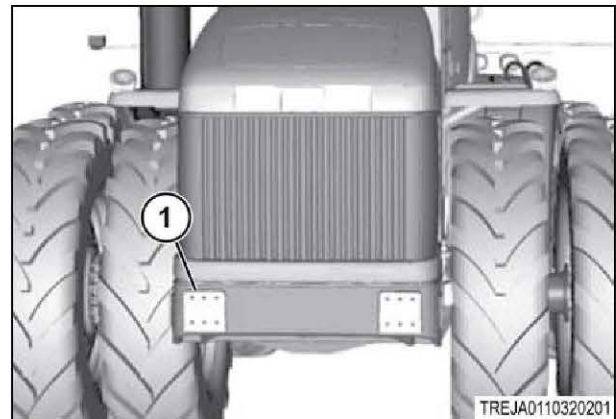

Fig. 30



Fig. 31

17. Attachments

3. Install the flagpin bolt (1) in the hole in the center of the front bracket. The flagpin bolt will prevent the front weights from shifting.

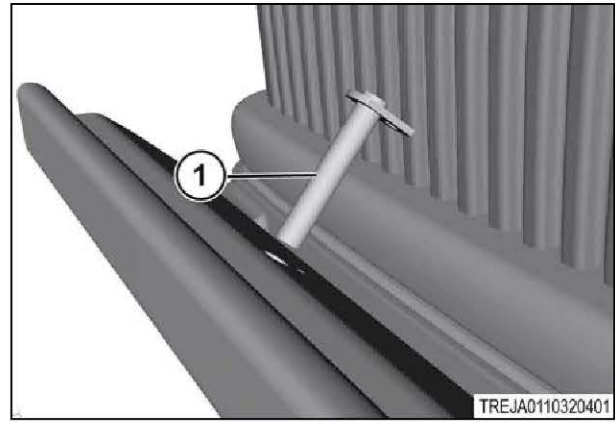

Fig. 32

4. Secure the flagpin bolt with bolt (1). Torque to 100 Nm.

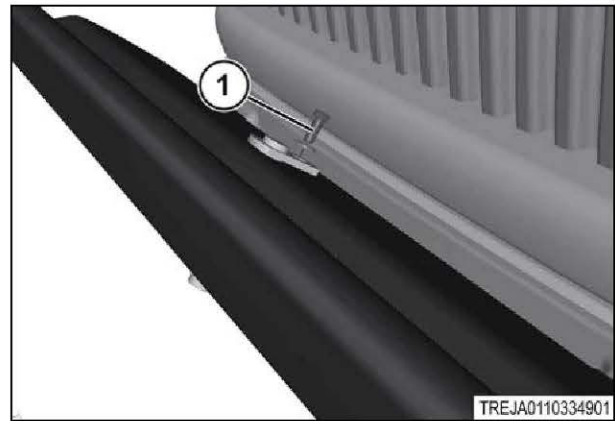

Fig. 33

5. Install the weights (1) to the front bracket. Make sure the flagpin bolt (2) is aligned with the hole in the weight.

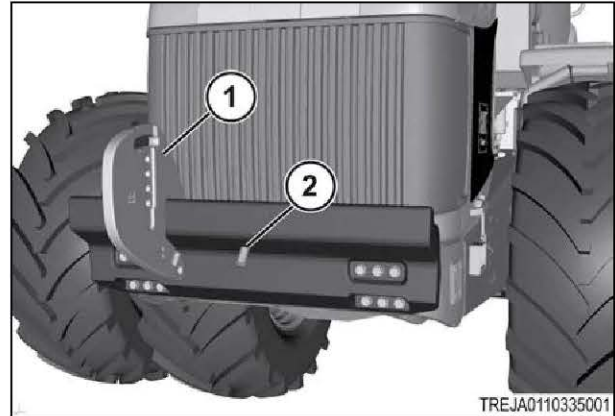

Fig. 34

6. Continue stacking weights (1) on both sides of the flagpin until the desired amount is installed.



Fig. 35

7. Install the plates (1) to fasten the bolts.



Fig. 36

8. Install the bolts (1) to secure the weights.

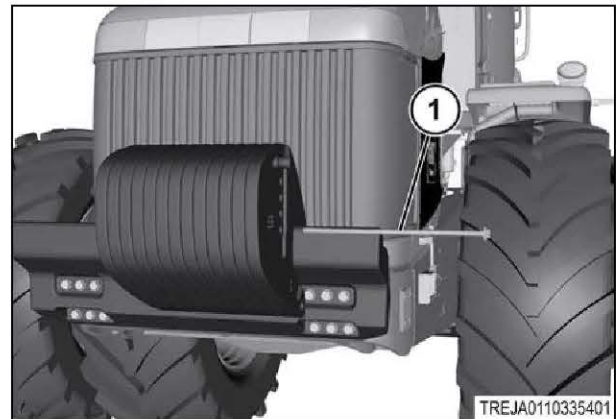

Fig. 37

9. For 20 weights, use two bolts (1) to attach the weights using two plates (2). Torque to 240 Nm.
10. Install the plates in opposite orientations.
11. Install six weights between the two plates

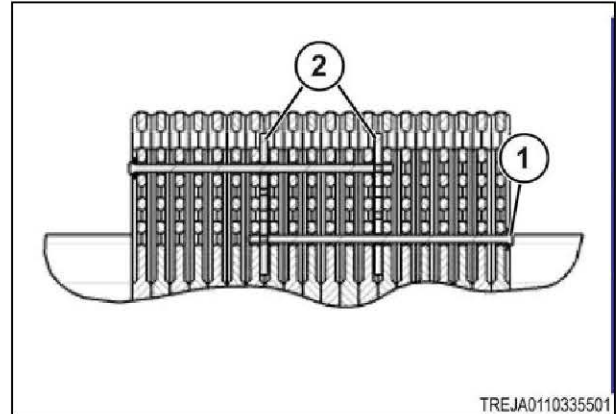

Fig. 38

12. For 32 weights, use six bolts (1) to attach the weights using three plates (2). Torque to 240 Nm.
13. Install the first two plates in the same orientation after installing six weights.
14. Install the third plate in the opposite orientation as the first two plates.
15. Install the third plate after another three weights are installed on same side.

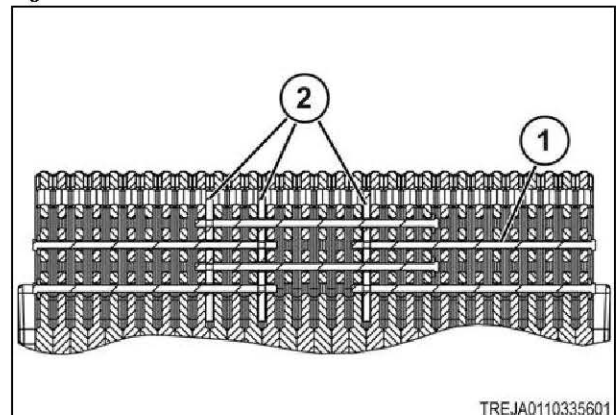

Fig. 39

17.4.3 Remove the wheel weights

Related Links

[Remove the outside wheel](#) page 14-3

[Remove the center wheel](#) page 14-4

[Remove the inside wheel](#) page 14-5

17.4.3.1 227 kg (500 lb)



WARNING:

Wheel weights are extremely heavy and require proper handling equipment to remove. Fully support and constrain the tire and the wheel assemblies before removing weights. Failure to use the correct procedures and the correct equipment can cause personal injury or death because of crushing.

NOTE: *Weight installation special tooling part number 332298*

Procedure

1. If only the outside weights (1) are being removed than removing the wheel is not necessary(2). Support the weight using the special tooling and an overhead crane. Remove the three bolts (3) and then remove the weight. Repeat the same procedure for the remaining wheels.

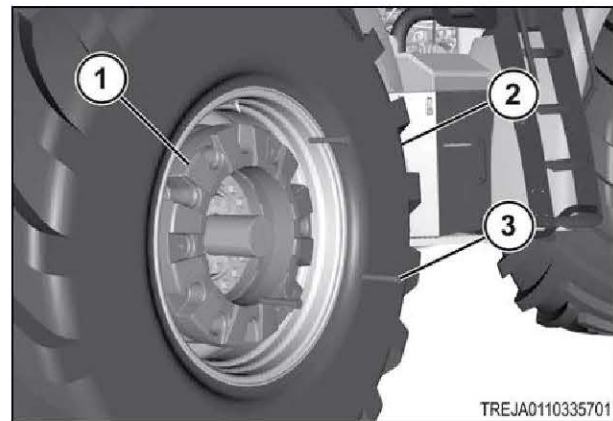
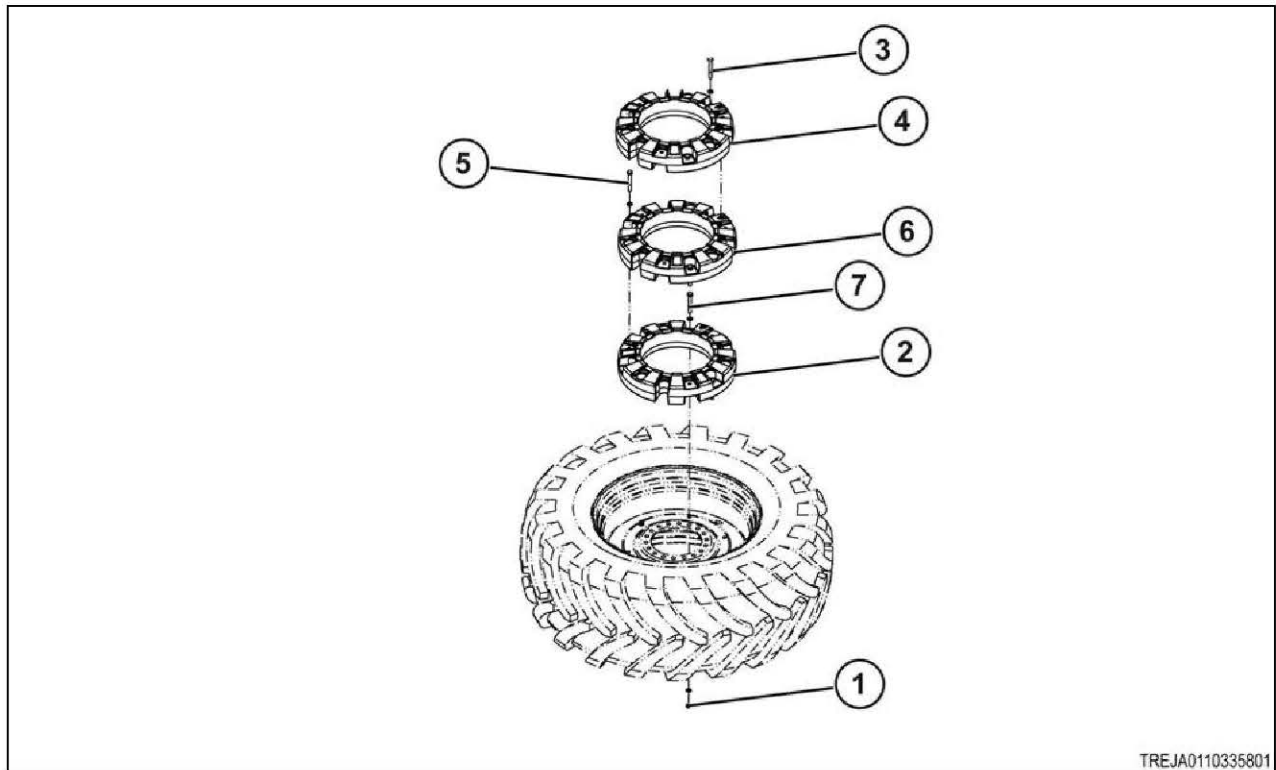

Fig. 40



TREJA0110335801

Fig. 41

2. The tire assembly must first be removed from the axle before the inside weights can be removed from the rim. Set the tire and the rim assembly on an elevated surface. Make sure there is access to the nut (1) that secures the inner weight (2).
3. Remove the three bolts (3) and then use a suitable lifting device to remove the outer weight (4). Remove the three bolts (5) and then use a suitable lifting device to remove the middle weight (6). Remove the three bolts (7) and then use a suitable lifting device to remove the inside weight (2).
4. Turn the wheel over and repeat the procedure to remove the weights. Repeat the same procedure for the remaining wheels.

17.4.3.2 364 kg (800 lb)

Procedure

1. If only the outside weights (1) are being removed than removing the wheel is not necessary(2). Support the weight using the special tooling and an overhead crane. Remove the three bolts (3) and then remove the weight. Repeat the same procedure for the remaining wheels.
2. The tire assembly must first be removed from the axle before the inside weights can be removed from the rim.



TREJA0110335901

Fig. 42

17. Attachments

3. Remove the three bolts (1) that secure the weight (2) to the rim. Turn the wheel over and repeat the procedure to remove the weights. Repeat the same procedure for the remaining wheels.
4. Remove the three bolts (1) and disassemble the weights.

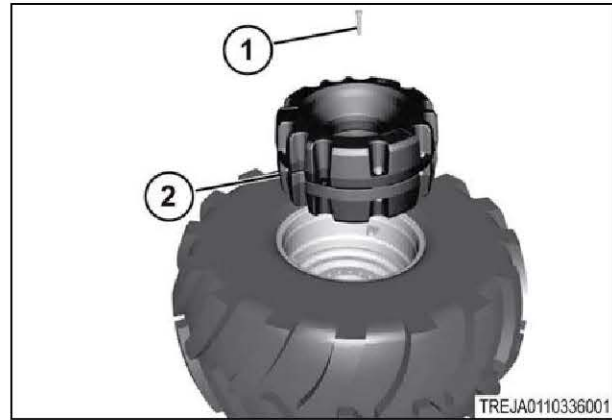

Fig. 43

17.4.4 Install the wheel weights

Related Links

- [Install the inside wheel](#) page 14-8
- [Install the center wheel](#) page 14-11
- [Install the outside wheel](#) page 14-13

17.4.4.1 227 kg (500 lb)



WARNING:
Wheel weights are extremely heavy and require proper handling equipment to remove. Fully support and constrain the tire and the wheel assemblies before removing weights. Failure to use the correct procedures and the correct equipment can cause personal injury or death because of crushing.

NOTE:

Weight installation special tooling part number 332298

Up to three 227 kg (500 lb) can be mounted together as an assembly. To help with assembly, do not assemble more than two weights together before installing the weights.

Procedure

1. The ballast needs vary according to the machine model, the implement being pulled, and the field conditions.
2. If only the outside weights (1) are to be installed, then removing the wheel (2) is not necessary. Support the weight using the special tools and an overhead crane. Move the weight into position. Mount the weight with three bolts (3) and tighten to 530 Nm (390 lbf ft). Repeat the procedure for the remaining wheels.
3. Install all the wheels.
4. Lower the machine to the ground.
5. Drive the machine for a minimum of ten minutes to seat the wheel weights. Operate the machine at 5 to 8 km/h (3 to 5 mph). Stop a minimum of five times using the service brake.
6. Check all of the counterweight bolts. Tighten all the counterweight bolts to 530 Nm (390 lbf ft).

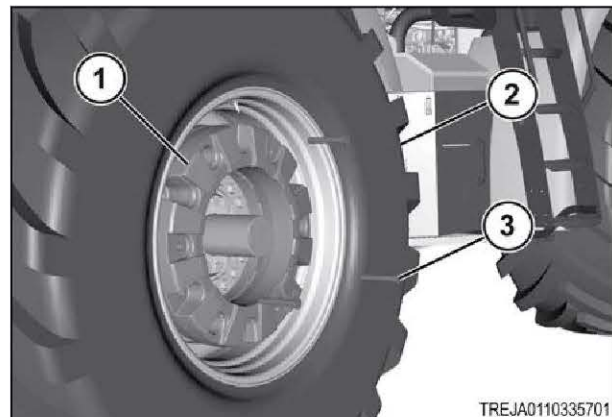

Fig. 44

7. Set the tire and the rim assembly (1) on an elevated surface. Make sure there is access to the nut (2) that fastenes the weight (3).
8. Use a correct lifting device to move the weight(s) into position on the rim. Install the weight with three bolts (4) and fasten with nuts and washers (5). Torque to 530 Nm (390 lbf ft).
9. Turn the tire over and install the desired amount of weights on the opposite side using the same procedure.
10. If a third weight needs to be installed, turn the tire and rim assembly over and install the third weight.
11. Repeat the same procedure for the remaining wheels.
12. Install the wheels.
13. Lower the machine to the ground.
14. Drive the machine for a minimum of ten minutes to seat the wheel weights. Operate the machine at 5 to 8 km/h (3 to 5 mph). Stop a minimum of five times using the service brake.
15. Make sure all the counterweight bolts do not rotate when tightened to 460 Nm (340 lbf ft). Tighten all the counterweight bolts to 530 Nm (390 lbf ft).

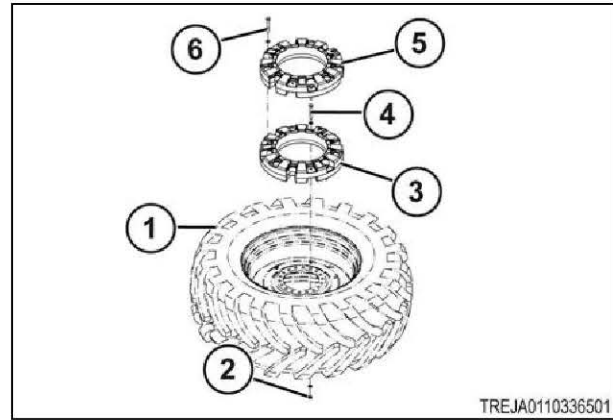

Fig. 45

17.4.4.2 364 kg (800 lb)



WARNING:

Wheel weights are extremely heavy and require proper handling equipment to remove. Fully support and constrain the tire and the wheel assemblies before removing weights. Failure to use the correct procedures and the correct equipment can cause personal injury or death because of crushing.

Up to four 364 kg (800 lb) weights can be used for wheel ballast on 35.5L-32 single tires.

NOTE:

Weight installation special tooling part number 332298

Procedure

1. Assemble the two weights together before mounting the wheel. Tighten all the bolts (1) to 530 Nm (390 lbf ft).



Fig. 46

IMPORTANT:

Tighten the bolts after ten hours of service and every 250 hour intervals after.

17. Attachments

2. Removing the wheel is not necessary if only the inside weights(1) are being installed(2).
3. Move the weight into position using a correct lifting device. Mount the weight with three bolts (3) and tighten to 530 Nm (390 lbf ft). Repeat the procedure for the remaining wheels.
4. Install all the wheels.
5. Lower the machine to the ground.
6. Drive the machine for a minimum of ten minutes to seat the wheel weights. Operate the machine at 5 to 8 km/h (3 to 5 mph). Stop a minimum of five times using the service brake.



Fig. 47

7. Check all of the counterweight bolts. Tighten all the counterweight bolts to 530 Nm (390 lbf ft).
8. The tire and rim assembly must be removed from the axle before installing the inside weights on the rim.
9. Use a correct lifting device to move the weight (2) into position on the rim. Install the weight with three bolts (1) and tighten to 530 Nm (390 lbf ft).

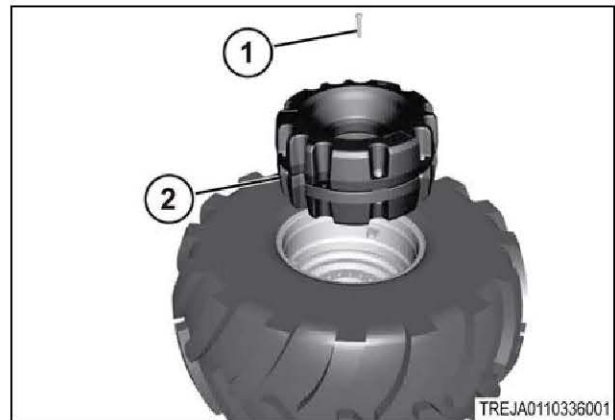

Fig. 48

10. Turn the tire over and install the desired amount of weights on the opposite side using the same procedure.
11. Repeat the procedure for the remaining wheels.
12. Install all the wheels.
13. Lower the machine to the ground.
14. Drive the machine for a minimum of ten minutes to seat the wheel weights. Operate the machine at 5 to 8 km/h (3 to 5 mph). Stop a minimum of five times using the service brake.
15. Make sure all the counterweight bolts do not rotate when tightened to 460 Nm (340 lbf ft). Tighten all the counterweight bolts to 530 Nm (390 lbf ft).

17.5 Toolbox

17.5.1 Remove the toolbox

Procedure

1. Park the machine on a solid, level surface. Stop the engine, apply the parking brake, and take the key with you.
2. Turn the battery disconnect switch key (1) counterclockwise to disconnect the battery power.

NOTE:

The battery disconnect switch is shown in the off position.

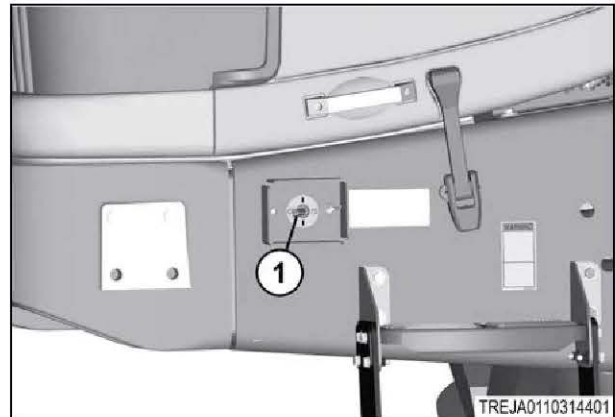

Fig. 49

3. Remove the battery disconnect switch key (1).

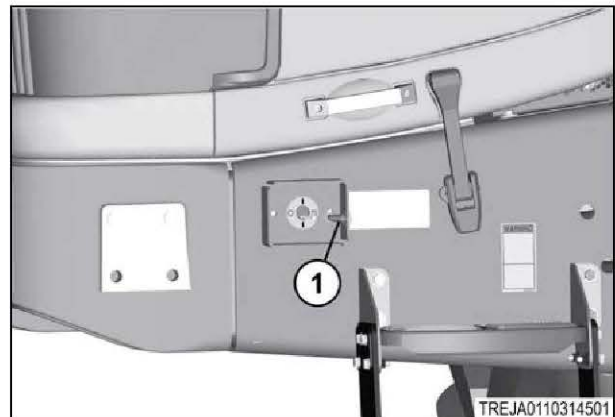

Fig. 50

4. Disconnect the latch (1), and open the toolbox cover.

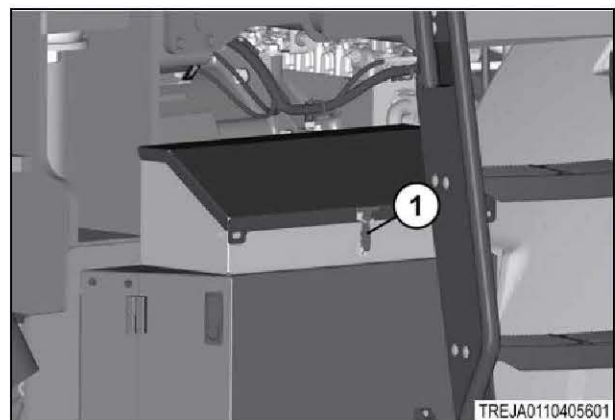

Fig. 51

17. Attachments

5. Remove the hardware (1), and the toolbox (2).

NOTE:

Some parts have been removed for clarity.

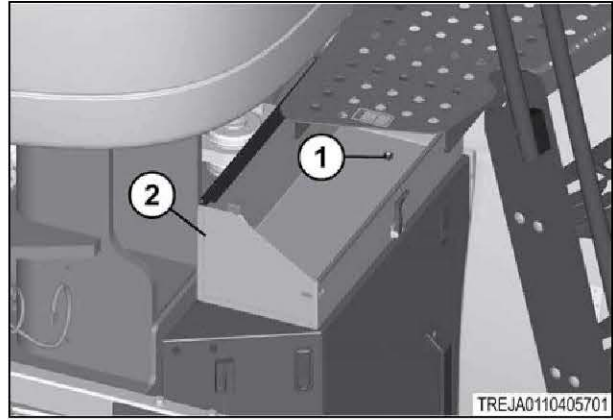

Fig. 52

17.5.2 Install the toolbox**Procedure**

1. Install the toolbox (2) with the hardware (1).

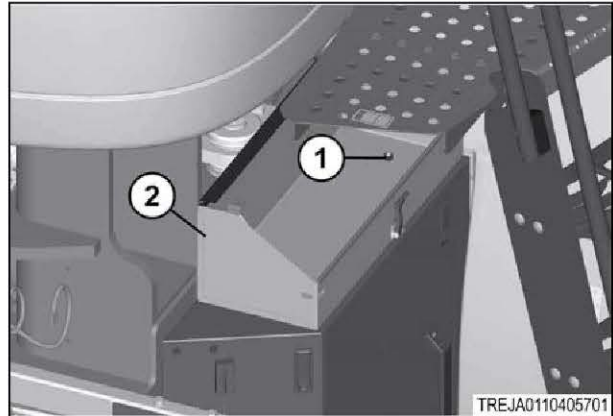

Fig. 53

2. Close the toolbox cover and connect the latch (1).

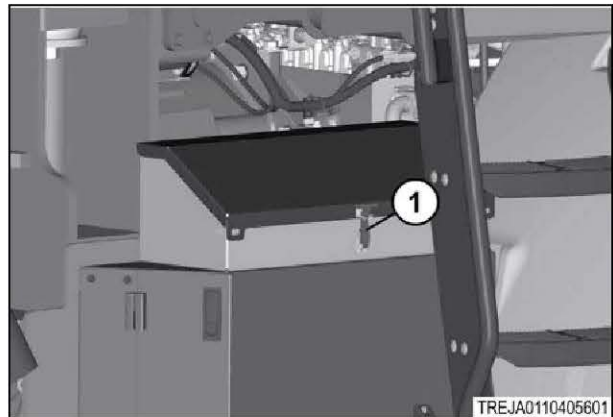

Fig. 54

3. Install the battery disconnect switch key (1).

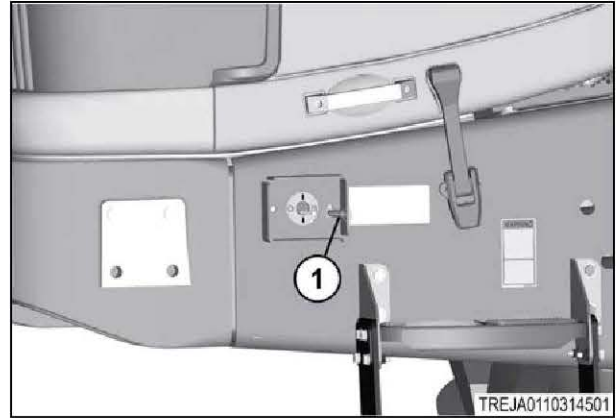

Fig. 55

4. Turn the battery disconnect switch key (1) clockwise to connect the battery power.

NOTE:

The battery disconnect switch is shown in the off position.

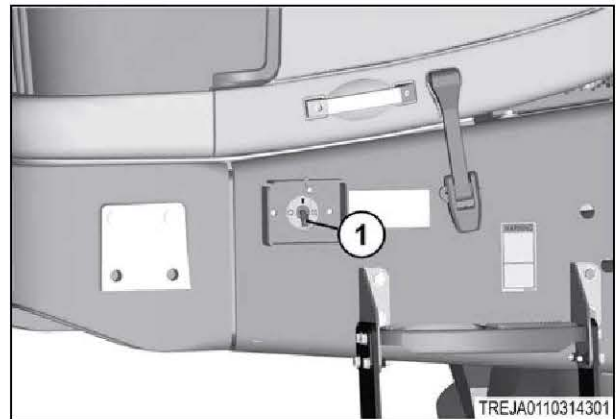

Fig. 56

17.6 Special application hitch

17.6.1 Remove the special application hitch

Procedure

1. Park the machine on a solid, level surface. Stop the engine, apply the parking brake, and take the key with you.
2. Turn the battery disconnect switch key (1) counterclockwise to disconnect the battery power.

NOTE:

The battery disconnect switch is shown in the off position.

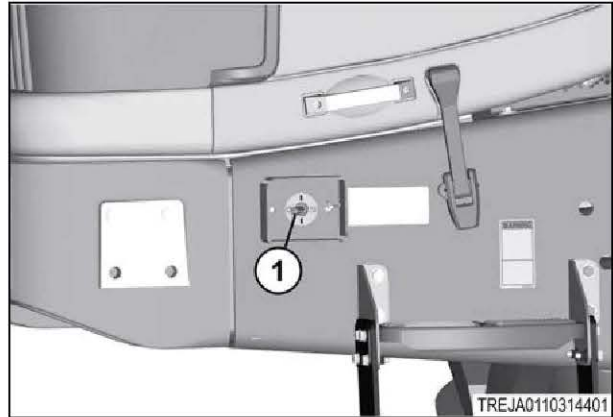

Fig. 57

3. Remove the battery disconnect switch key (1).

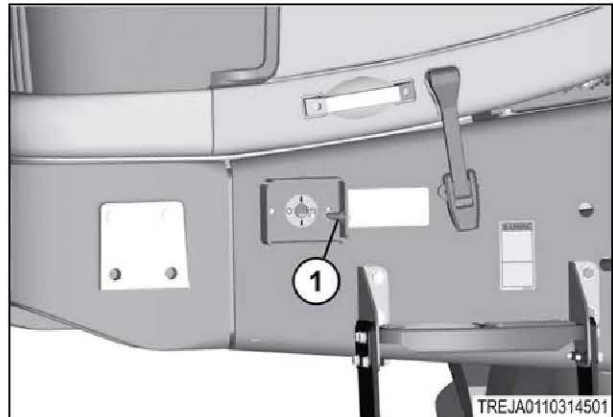

Fig. 58

4. Remove the hardware (1) and the trailer connector bracket assembly (2).

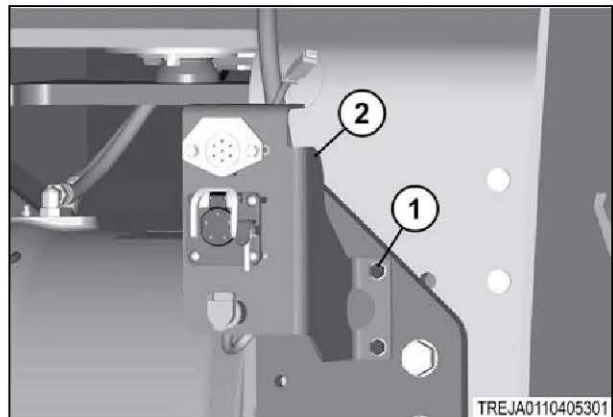

Fig. 59

5. Remove the implement valve bank (1).
6. Fasten the correct lifting equipment to the special application hitch.

IMPORTANT:

The weight of the special application hitch is approximately 120 kg (265 lb).

7. Remove the hardware (1), and the special application hitch (2).

8. Remove the hardware (1), and the drawbar pin (2), from the drawbar (3).

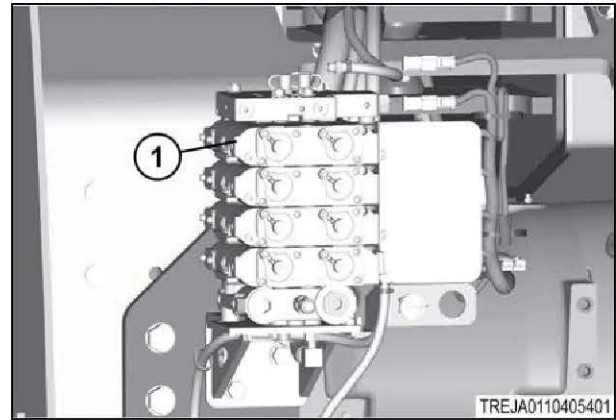

Fig. 60

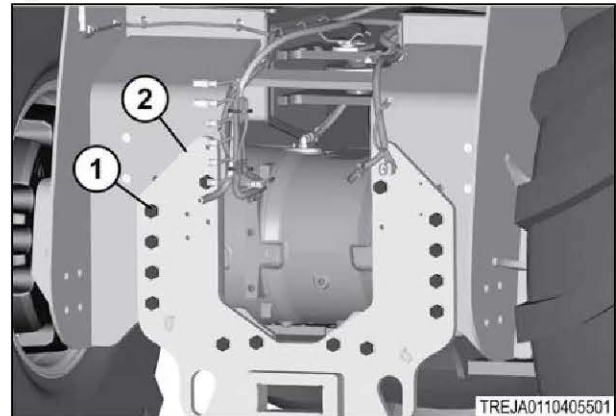

Fig. 61

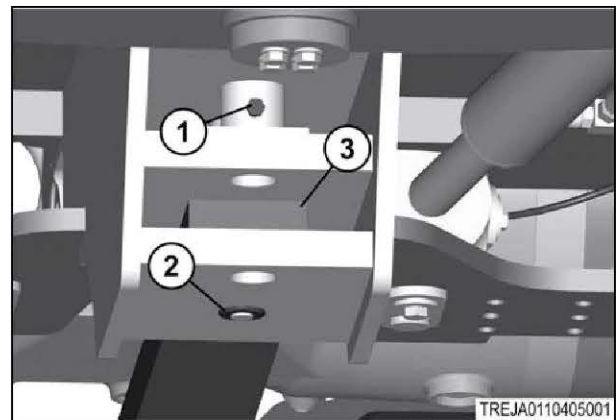

Fig. 62

Related Links

[Removing the implement control valves - drawbar configuration](#) page 9-84

17.6.2 Install the special application hitch

Procedure

1. Install the drawbar pin (2), to the drawbar (3), with the hardware (1).
2. Fasten the correct lifting equipment to the special application hitch.

IMPORTANT:

The weight of the special application hitch is approximately 120 kg (265 lb).

3. Install the special application hitch (2) with the hardware (1).
Tighten the hardware to 800 to 1000 Nm (738 lbf ft).

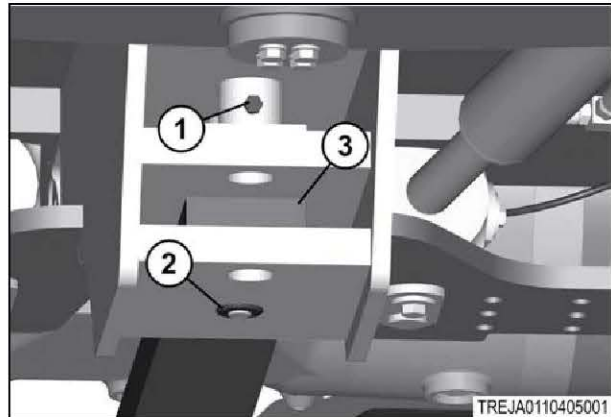

Fig. 63

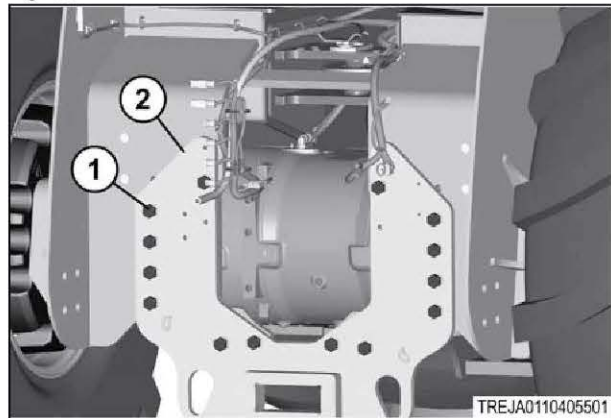

Fig. 64

4. Install the implement valve bank (1).

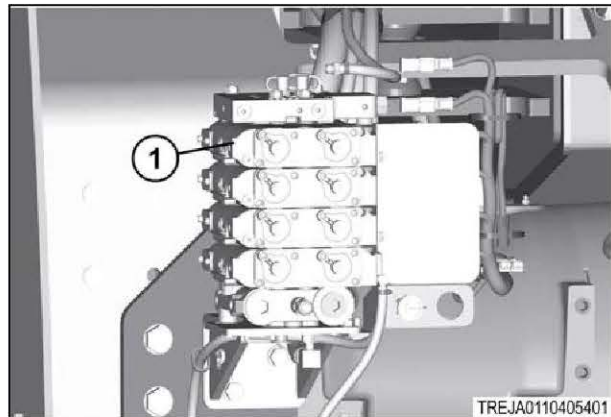

Fig. 65

5. Install the trailer connector bracket assembly (2) with the hardware (1).
Tighten the hardware to 48 to 72 Nm (35 to 53 lbf ft).

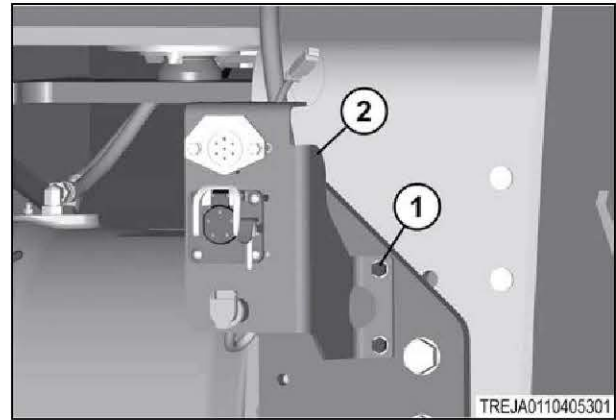

Fig. 66

6. Install the battery disconnect switch key (1).

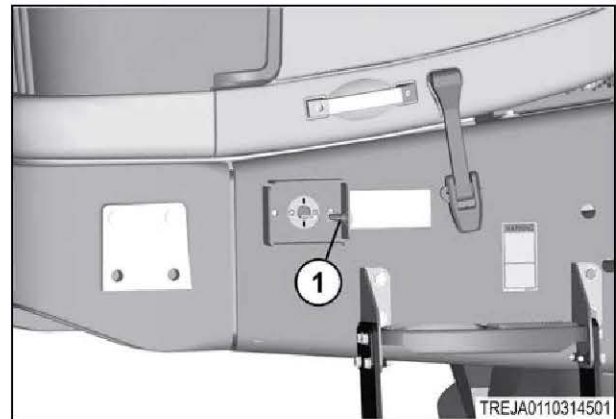

Fig. 67

7. Turn the battery disconnect switch key (1) clockwise to connect the battery power.

NOTE:

The battery disconnect switch is shown in the on position.

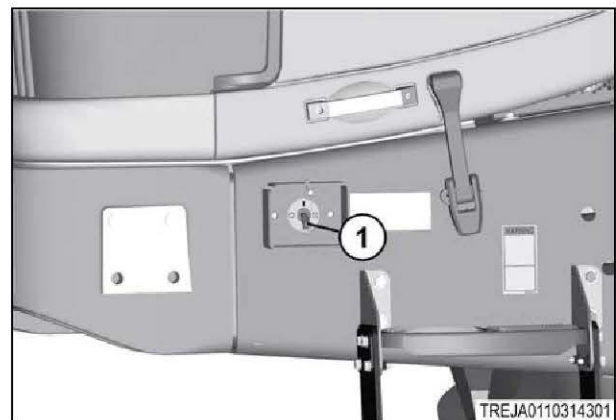

Fig. 68

Related Links

[Installing the implement control valves - drawbar configuration](#) page 9-87

17.7 Tow cable

17.7.1 Remove the tow cable

Procedure

1. Park the machine on a solid, level surface.
2. Apply the parking brake, stop the engine, and take the key with you.
3. Turn off the battery disconnect switch key (1).
4. Remove the battery disconnect switch key (1).
5. Release the lock (1) and remove the tow cable (2).
6. Remove the hardware (3), and the tow cable support assembly (4).
7. Remove the hardware (1), the pin (2), and the tow cable (3).
8. Remove the hardware (1), the cable support (2), and the clevis link (3) with chain.

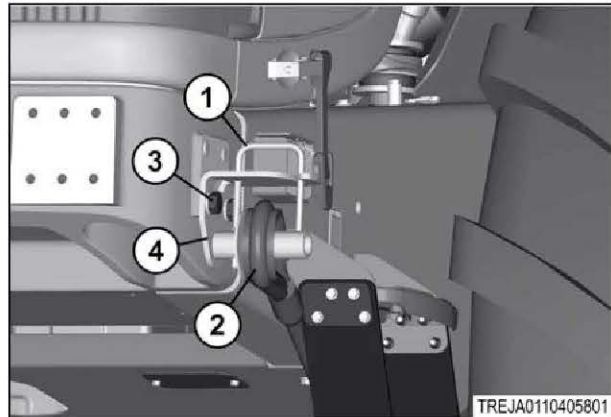

Fig. 69

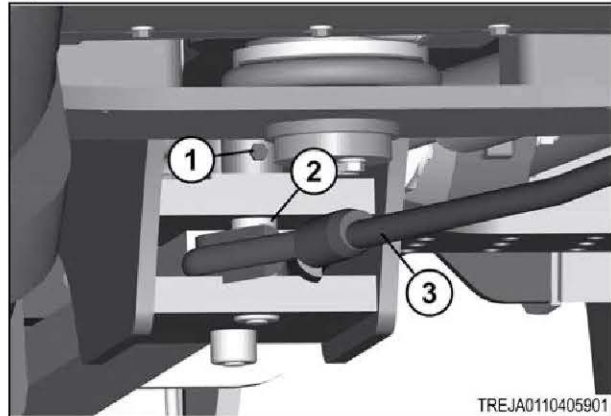

Fig. 70

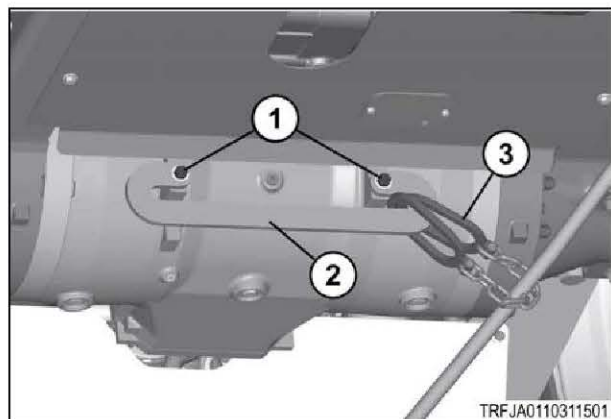

Fig. 71

17.7.2 Install the tow cable

Procedure

1. Install the tow cable (3), with the pin (2), and the hardware (1).
2. Install the tow cable support assembly (4), with the hardware (3).
3. Install the tow cable (2), and connect the lock (1).
4. Install the chain around the tow cable, and connect the clevis links (3) to the cable support.
5. Use the hardware (1) to install the cable support (2).
6. Install the battery disconnect switch key (1).
7. Turn on the battery disconnect switch key (1).

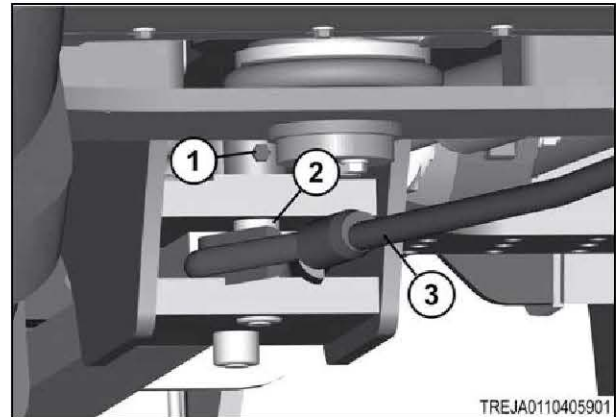

Fig. 72

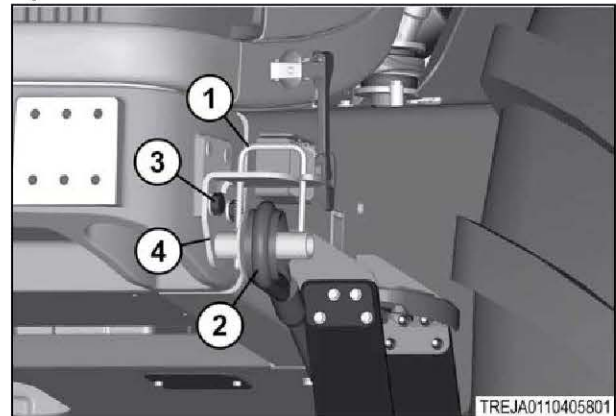

Fig. 73

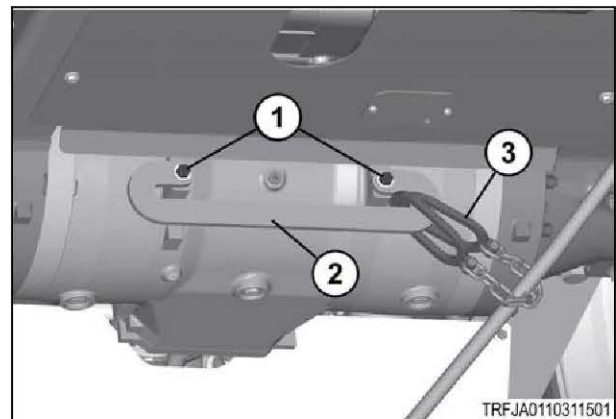

Fig. 74